

AIR COOLED
DIESEL ENGINES

L-A series
2.5~7.4kW(3.4~10hp)

YANMAR

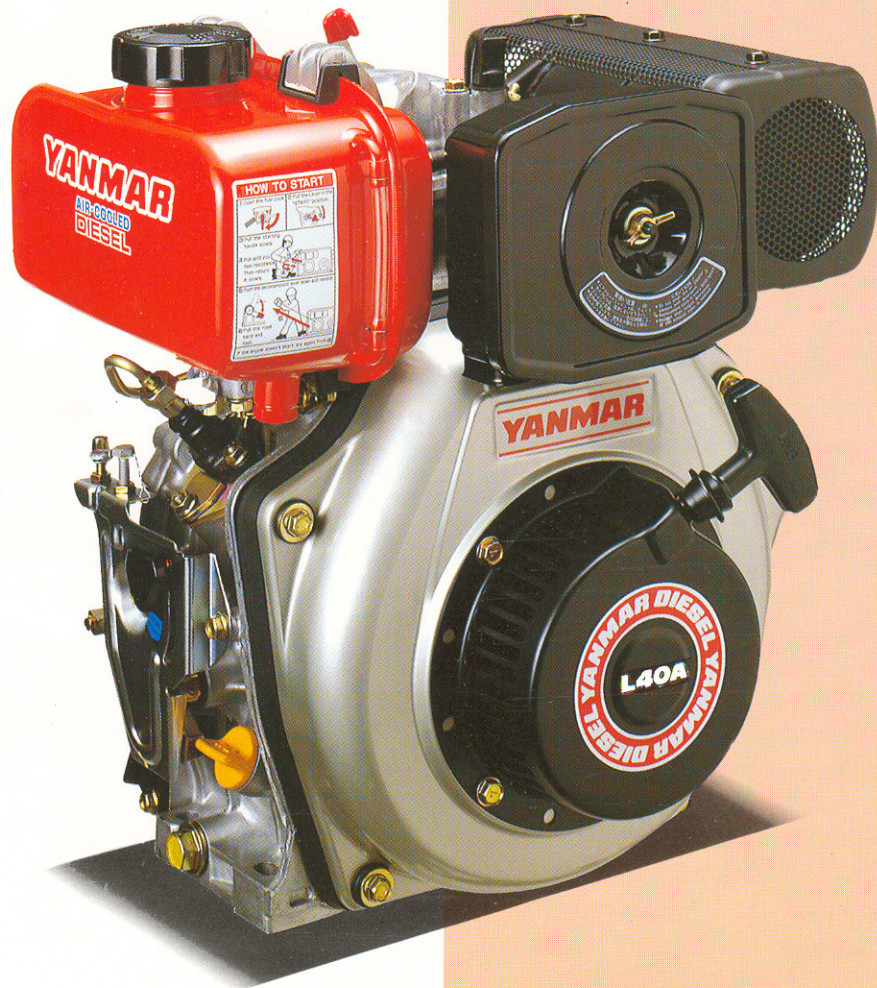

The Dream of a Diesel B

The total FIE expertise only a complete diesel maker can provide.

Yanmar developed the miniaturized fuel injection system, one of the world's smallest. We have since raised it to a level of efficiency that ensures you maximum power from every drop of diesel. Its extraordinarily low fuel consumption is a result of this super-precise FIE and its direct injection system — the first ever to go into this type of engine.

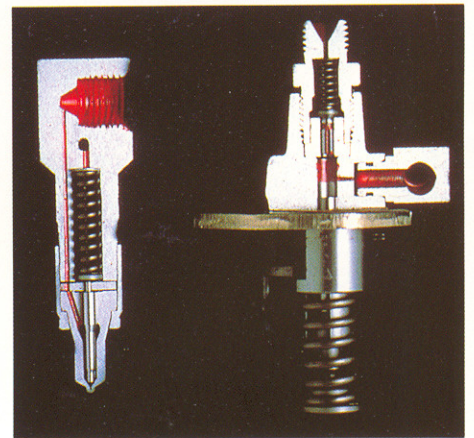

Its many special merits now include Yanmar's latest 'gentle' gears

Since this diesel was the first of its kind in the world, its original technology has given birth to a new generation of refinements.

For one, the new L-A series now extends its advantages over other air-cooled diesels with a significant drop in dB levels. It dose it with highly refined soft-contact gearing and a new, ultra-effect muffler. Features that can quietly help your product sell itself as no other can.

There's also a greater selection, a full line-up of seven models from 3.4hp to 10hp. And there are still the many 'firsts' that made Yanmar air cooled diesels such a hit with so many equipment makers



ecomes Slumber Silent

A little engine built to stand up to hard work.

The design, structure and materials of the L-A combine to form a rugged, hard working machine. With tough but lightweight alloys used for main engine parts, an extra tough crankshaft and an overall simplified structure the L-A is a compact package of power.

Fast, effortless starts from a one-pull recoil starter.

A short and smooth pull of the toggle kicks off the engine, as simple as a gasoline model. It is made easy by a special auto-return decompressor and Yanmar's own efficient combustion system. Electric starting is also a useful option.

Larger engine range with multi-choice PTO shafts

The L-A's range of utility has been greatly broadened by the addition of low and high end models. This makes a selection of 7 different models with a choice of 4 kinds of PTO coupling available. Wherever compact and economical drive is needed the L-A fits the bill, giving the long-term dependability only diesels can offer.



The long runner!

Start it and leave it. Operates longer hours — thanks to the large lube oil sump. A rugged mover for remote locations on any worksite. Special oil pan allows running on slopes up to 30°

OIL PAN CAPACITY

Model	L40ABE-D	L60ABE-D
Oil pan capacity (effective/total:ℓ)	2.0/2.8	2.2/3.0
Oil supply interval (hr.)	600	500
Allowable inclination angle (continuous/instantaneous)	*20/30 degree (standard specification)	

*Operation inclination angle.

The large-capacity oil pan may be designed for an allowable inclination angle of 40° max. at your request.

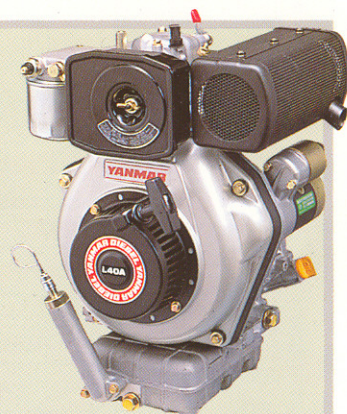

SPECIFICATIONS

Model		L40AE	L48AE	L60AE	L70AE	L75AE	L90AE	L100AE
Type		Single-cylinder, vertical 4-cycle air-cooled diesel						
Combustion system		Direct injection						
Displacement	cc (cu.in.)	199 (12.14)	211 (12.88)	273 (16.66)	296 (18.06)	351 (21.42)	387 (23.62)	406 (24.78)
Bore × stroke	mm (in.)	68 × 55 (2.68 × 2.17)	70 × 55 (2.76 × 2.17)	75 × 62 (2.95 × 2.44)	78 × 62 (3.07 × 2.44)	80 × 70 (3.15 × 2.76)	84 × 70 (3.31 × 2.76)	86 × 70 (3.39 × 2.76)
Engine speed	rpm	3000	3600	3000	3600	3000	3600	3000
Maximum output	hp	3.8	4.2	4.2	4.7	5.5	6.0	6.1
Continuous output	hp	3.4	3.8	3.8	4.2	5.0	5.5	5.5
Power take off		Crankshaft or camshaft (Camshaft PTO rpm is 1/2)						
Starting system		Recoil or Recoil/Electric						
Fuel tank capacity	ℓ (U.S. gal.)	2.5(0.66)	2.5(0.66)	3.5(0.92)	3.5(0.92)	5.5(1.45)	5.5(1.45)	5.5(1.45)
Lub. oil capacity	ℓ (U.S. gal.)	0.8(0.21)	0.8(0.21)	1.1(0.29)	1.1(0.29)	1.65(0.44)	1.65(0.44)	1.65(0.44)
Dimensions (D spec.)	L	mm (in.)	332 (13.07)	332 (13.07)	383 (15.08)	383 (15.08)	417 (16.42)	417 (16.42)
	W	mm (in.)	392 (15.43)	392 (15.43)	421 (16.57)	421 (16.57)	470 (18.50)	470 (18.50)
	H	mm (in.)	416 (16.38)	416 (16.38)	450 (17.72)	450 (17.72)	494 (19.45)	494 (19.45)
Dry weight (Recoil)	kg (lbs.)	26 (57)	26 (57)	33 (73)	33 (73)	48 (106)	48 (106)	48 (106)
Dry weight (Electric)	kg (lbs.)	31 (68)	31 (68)	38 (84)	38 (84)	53 (117)	53 (117)	53 (117)

PERFORMANCE CURVES

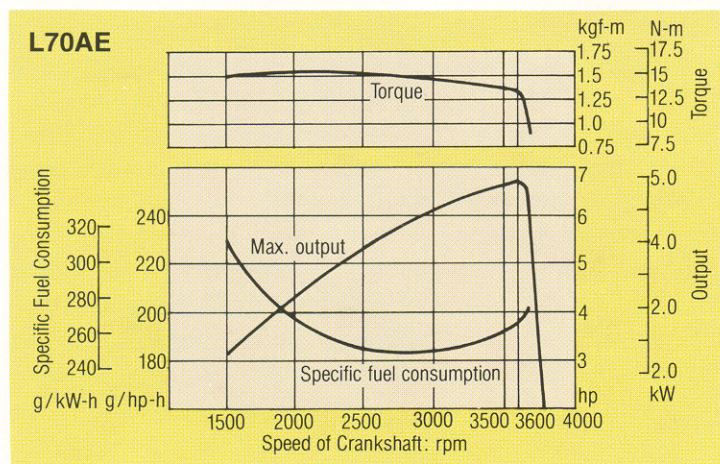
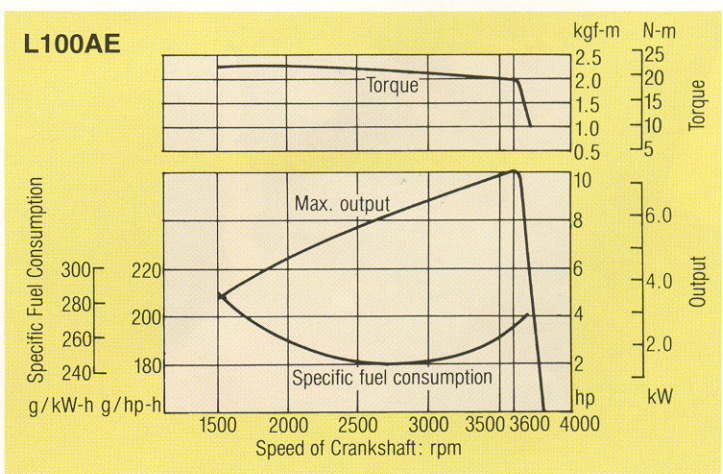
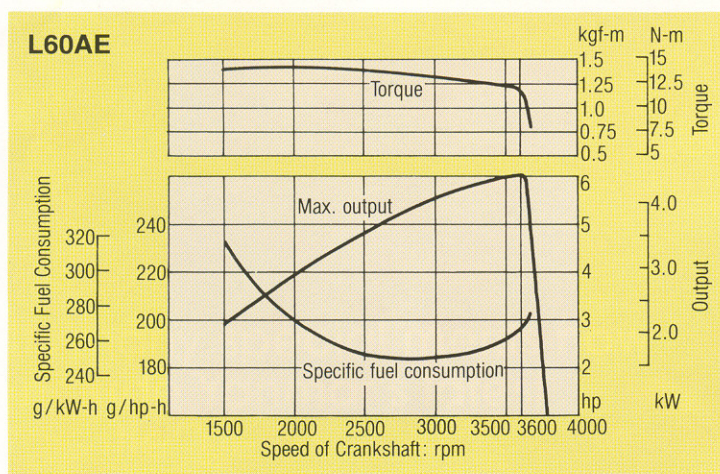
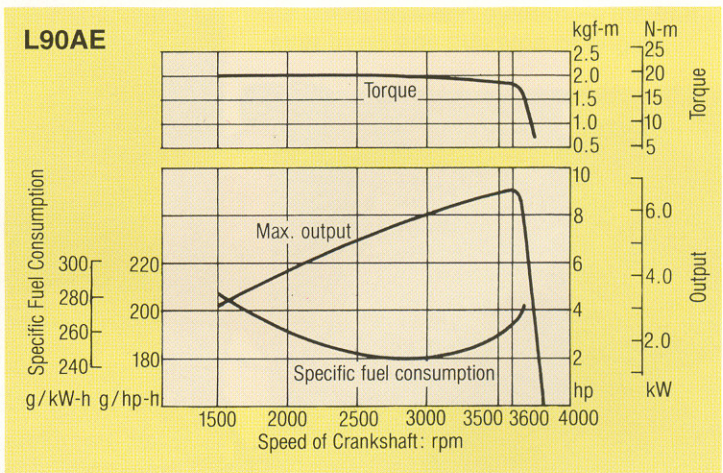
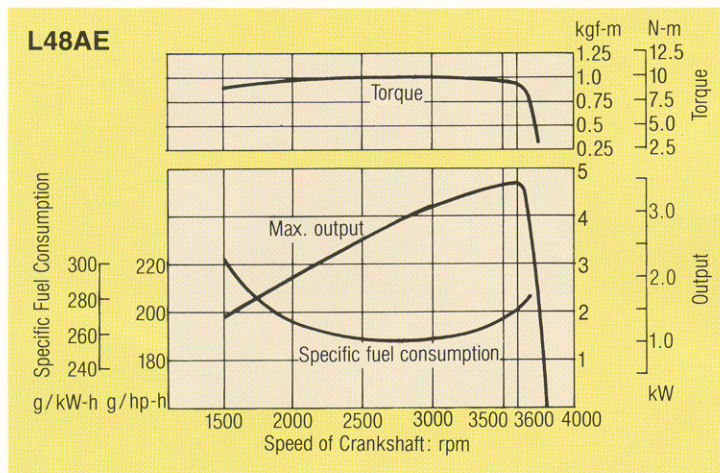
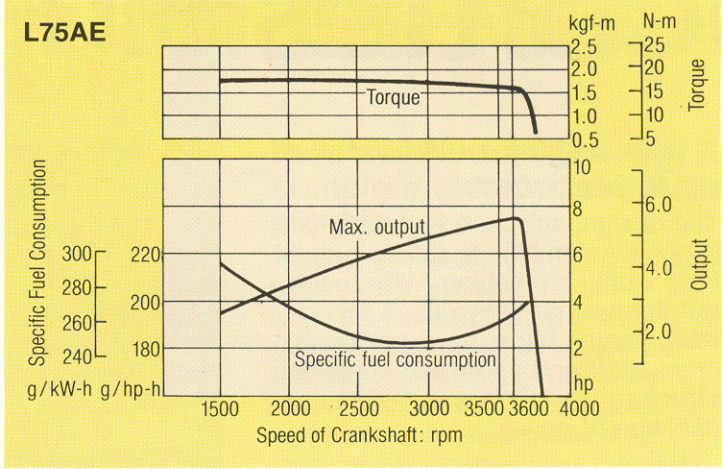
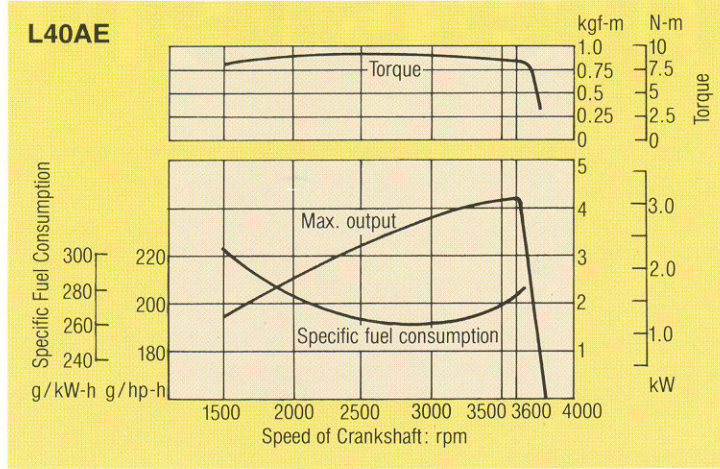

Performance measured after 30hrs running-in, with air cleaner and exhaust silencer.

Atmospheric conditions: **ISO 3046/1**
 Intake air temperature: 20°C (293K) [27°C (300K)]
 Barometric pressure: 760mmHg [750mmHg]
 Relative humidity: 60% [60%]

ENGINE DIMENSIONS

Unit:mm(in.)

L40AE/L48AE

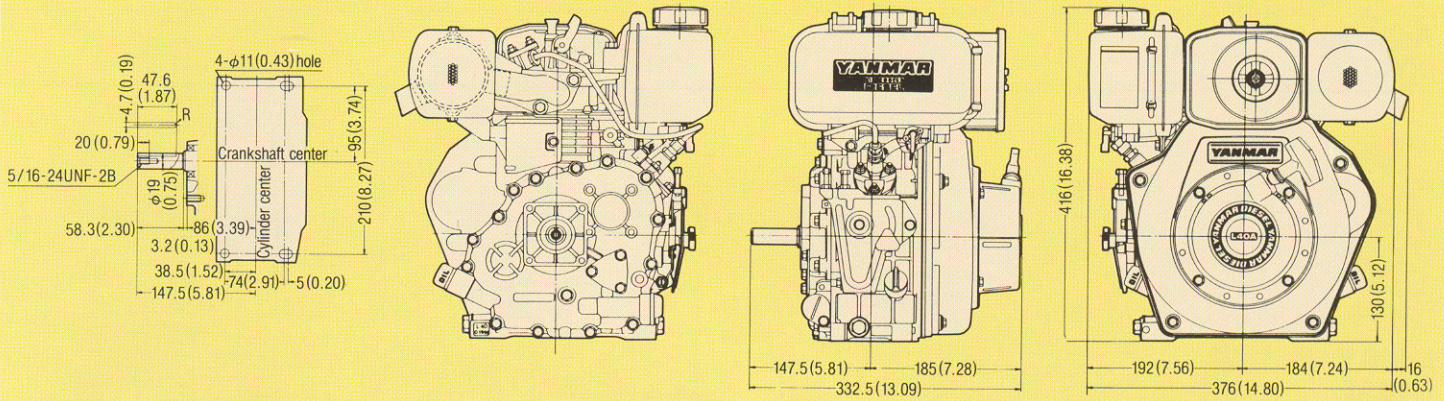

L60AE/L70AE

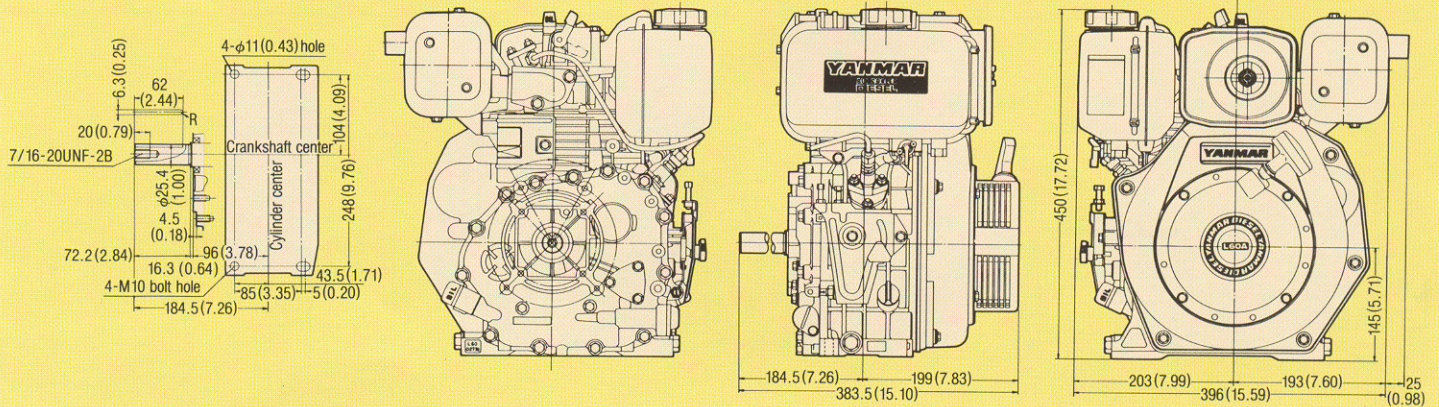

L75AE/L90AE/L100AE

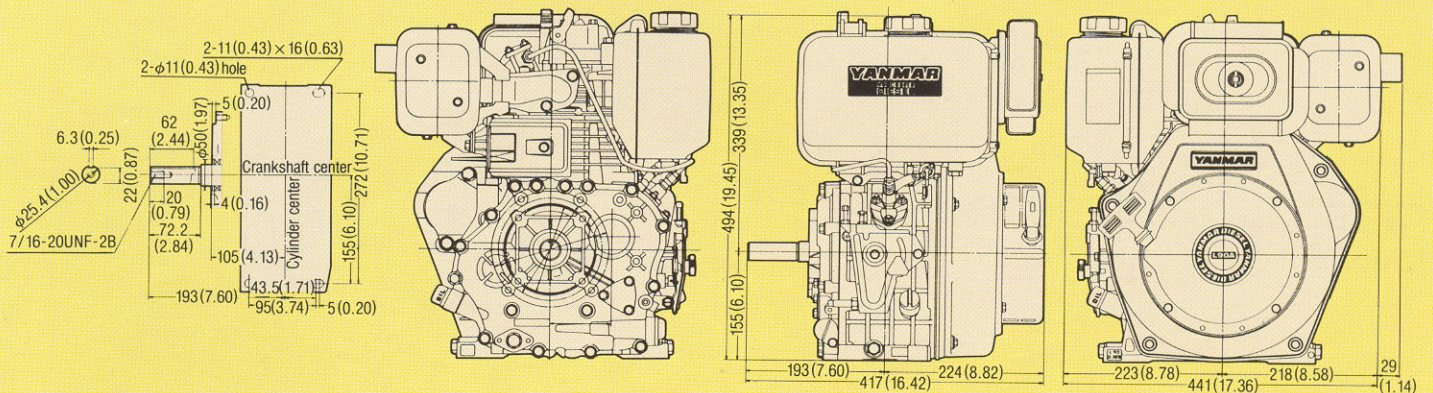

PTO DIMENSIONS

Type	Crankshaft PTO		
	Keyway shaft	Thread shaft	Taper shaft
Application code	D	DP	DG
L40AE L48AE			
L60AE L70AE			
L75AE L90AE L100AE			

Camshaft PTO

Keyway shaft

S

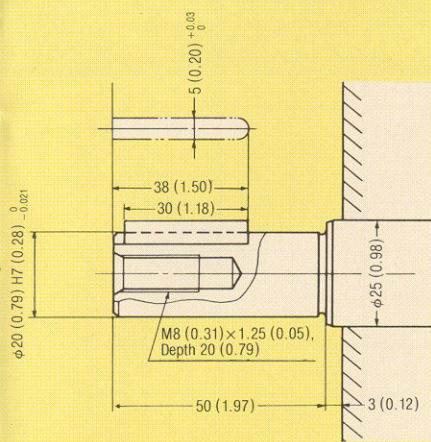

D

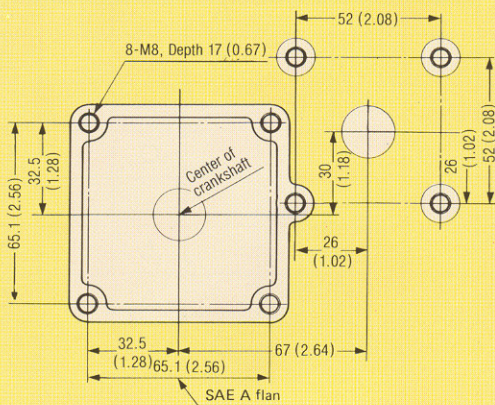

S

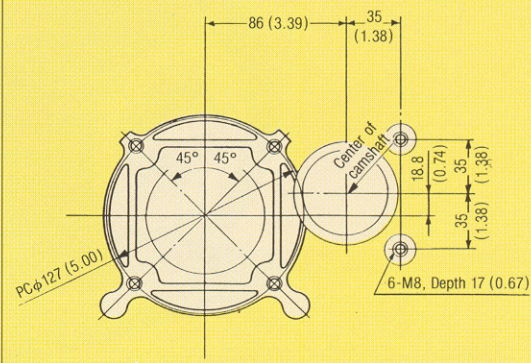
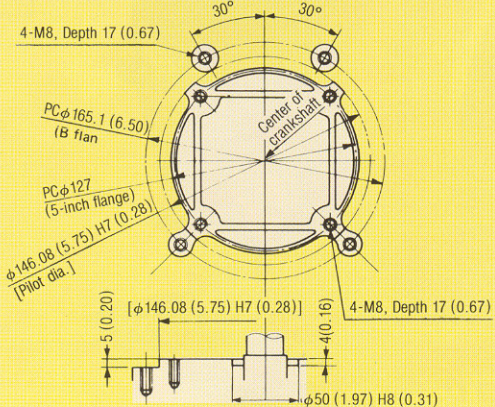
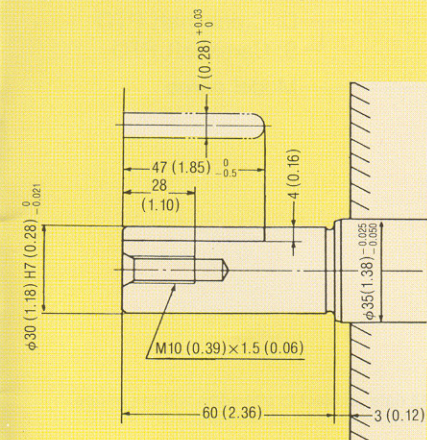
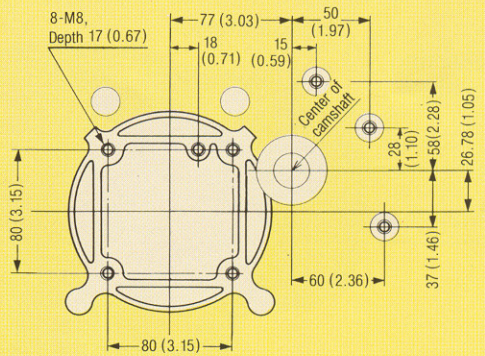
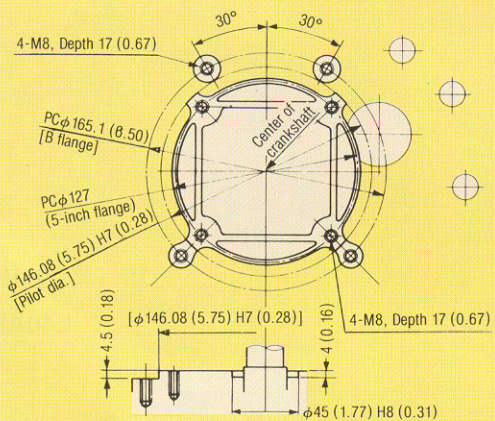
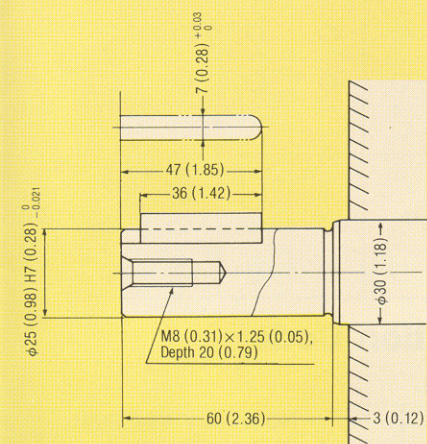
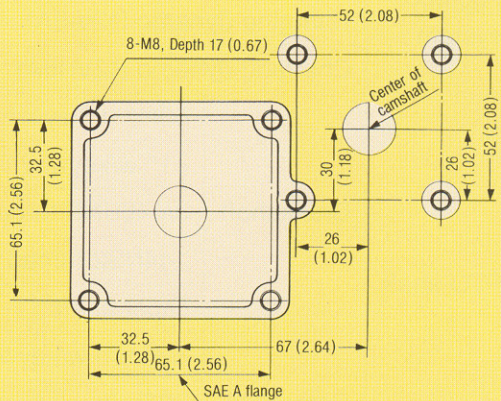

ACCESSORIES

○: Standard △: Option

Model		L40AE/L48AE				L60AE/L70AE				L75AE/L90AE/L100AE			
Application code		D	S	DE	SE	D	S	DE	SE	D	S	DE	SE
Fuel system	Fuel tank (2.5 liter)	○	○	○	○								
	Fuel tank (3.5 liter)	△	△	△	△	○	○	○	○				
	Fuel tank (5.5 liter)					△	△	△	△	○	○	○	○
	Fuel filter	○	○	○	○	○	○	○	○	○	○	○	○
Electric system	Charging dynamo (12V-1A)			○	○			○	○			○	○
	Charging dynamo (12V-3A)			△	△			△	△			△	△
	Charging dynamo (12V-15A)			△	△			△	△			△	△
PTO shaft	Crankshaft	φ3/4" w/keyway	○		○								
		φ1" w/keyway					○		○		○		○
		3/4-16UNF thread	△		△								
		1-14NS2 thread					△		△		△		△
	Camshaft	φ20mm w/keyway		○		○							
		φ25mm w/keyway						○		○			
		φ30mm w/keyway										○	
													○
Intake & exhaust	Air cleaner	○	○	○	○	○	○	○	○	○	○	○	○
	Exhaust muffler	○	○	○	○	○	○	○	○	○	○	○	○
Starting system	Recoil starter	○	○	○	○	○	○	○	○	○	○	○	○
	Starting motor			○	○			○	○			○	○
	Key switch for 3/15A dynamo			△	△			△	△			△	△
Speed control knob	○	○	○	○	○	○	○	○	○	○	○	○	
Maintenance tools	○	○	○	○	○	○	○	○	○	○	○	○	

Application Code:

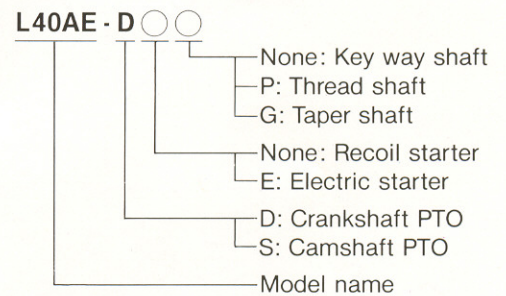

Note: All data subject to alteration without notice.

YANMAR DIESEL ENGINE CO., LTD.



1-32, Chayamachi, Kita-ku, Osaka 530-8311, Japan

Telephone: 06 6276 6411 Facsimile: 06 6277 1242