

OPERATING SEQUENCE FOR DIESEL GENERATING SET CONTROL #612-4792

Starting Circuit

The common practice for placing "Onan" Class "A" controls into operating condition is by grounding certain components. The switch is used to place this ground on the affected components.

Moving the handle of the manifold heater switch S12 to the preheat position causes a current flow from B+, through the coil of manifold heater solenoid K13 to ground and back to battery negative terminal. This causes manifold heater relay K13 to energize and closes its contacts to supply power to the manifold intake heater and glow plugs. If the preheat circuit is controlled by a load transfer control, this relay is energized by the grounding of terminal "H." The length of preheat can be selected through the use of a relay or through manually holding heater switch S12 on.

After the preheat period has passed, the load transfer control will cause terminal 3 to be grounded energizing the starting circuit. The starting circuit can also be energized by placing start-stop switch S11 in the start position. This allows battery current to flow from the B+ through start solenoid relay coil K11, through the closed contacts of the start-disconnect and fuel solenoid relay K12, through the start switch S11, to the center terminal to ground and to the battery causing start solenoid K11 to energize. K11 start solenoid energizes and causes its main contacts to close, connecting the battery through the cranking motor. At the same time the main contacts of K11 are closed, an auxiliary circuit is also completed from start solenoid K11 through the contacts of the emergency time delay relay K14, to the fuel solenoid K1, and to the battery. The fuel solenoid K1 is a two coil unit with a pickup coil and a holding coil. This relay energizes to take pressure off the control arm of the fuel injection pump and allows the metering sleeve to be positioned so fuel is supplied to the injectors so the engine can fire, start and run.

When the engine has started and accelerated to approximately 900 RPM, the centrifugal disconnect switch S1 closes. When switch S1 closes, battery current flows through its contacts, through resistor R11, through the coil of the start-disconnect and fuel solenoid relay K12 to the battery. This causes the K12 relay to energize and

breaks the circuit to the start solenoid relay K11 causing the start solenoid K11 to de-energize and remove the cranking motor from the battery. At the same time, another set of K12 contacts close supplying power from the charging circuit or the battery through the normally closed contacts of emergency relay K14 to the fuel solenoid K1. This keeps relay K1 (fuel solenoid) energized and allows the governor to control the fuel injection pump.

The engine governor will maintain engine speed at approximately 1860 RPM (62 cycles) or a fairly constant speed with load added.

The voltage buildup of one pole face on the exciter field assembly has a permanent magnet imbedded in it. This is installed at the time the lamination stack is assembled. This permanent magnet aids in the voltage build-up in the exciter. The residual magnetism of the pole pieces plus the permanent magnet in the one pole, causes a higher residual voltage to be produced. This produces, in the three phase exciter rotor, a voltage which is rectified by a network of three positive and three negative diodes to the generator rotor for field excitation. The voltage produced in the stator is supplied to the voltage regulator which controls the turn on point of the SCR's and in turn controlling field current. When the generator's voltage reaches the control point, the voltage regulator maintains field current to hold essentially constant output voltage.

Battery Charging Circuit

A separate battery charge winding is placed in the generator stator and has a voltage produced in it dependent upon the field strength of the main generator. The charging current is controlled by resistor R21. This charging circuit is essentially a 5 ampere circuit. Battery charging current is supplied through diode CR11 to the ammeter and to the battery back to ground and to the charging winding. This charges the battery and prepares it for supplying power for the next start. The charge winding also supplies power to maintain the fuel solenoid K1, energized.

Low Oil Pressure Cut-Out (LOPKO)

The low oil pressure cutout circuit is from the battery side of the ammeter through the centrifugal disconnect switch S1 to resistor R12, through the heater of the emergency time delay relay K14 and through the low oil pressure switch S4 to ground. Resistor R12 sets the timing interval of emergency relay K14. Should there be a loss of oil pressure or an excessive drop in level, switch S4 will close and the emergency time delay relay K14 will operate in approximately 15 seconds. When time delay relay K14 operates due to low oil pressure, its normally closed contacts open and break the circuit to the fuel solenoid K1. The fuel solenoid de-energizes and its plunger drops down on the control arm of the fuel injection pump causing the fuel to spill and shuts down the engine.

Unit Stopping

To stop the engine it is necessary to ground terminal #2 through the load transfer control or to place start-stop switch S11 in the stop position. Grounding terminal #2 or placing start-stop switch S11 in the stop position causes a ground to be placed on the supply side of the start-disconnect and fuel solenoid relay K12. Relay K12 de-energizes, its contacts open and break the circuit to the fuel solenoid K1 causing engine shutdown. Resistor R11 is placed in the circuit so a short circuit or direct ground is not placed on the battery charging circuit.

Fast Troubleshooting

If the ammeter does not indicate a charge, it usually means the generator has not built up voltage. This generator does not have an automatic field flash circuit; and consequently, it is necessary to make a field voltage measurement. This can be done across terminals 3 and 4 at the end bell of the generator or at terminal 7 or 8 of the voltage regulator assembly. Terminal 8 is positive and terminal 7 is negative. Should no voltage be measured at these points, refer to the "YD" Generator Service Manual (900-0184).

The water-cooled units have a high water temperature cutoff switch S2 in series with the fuel solenoid K1. This switch can be checked by placing a jumper across the terminals of the switch and closing the start switch S11 to see if the solenoid energizes.

If there has been a low oil pressure cutout condition, the red button on the emergency relay K14 will be sticking out. One minute of "cool down" is required before resetting (pushing in the button) the relay to place it back in operation. A shorter time may result in the solder pot not fusing correctly and permitting the button to be pushed out by the spring when the unit vibrates.

Should the centrifugal switch S1 fail to close or make contact, the start-disconnect and fuel solenoid relay K12 will de-energize as soon as the start switch S11 is released and then the unit will shut down. This causes a cycling condition on the generator set. The centrifugal switch S1 can be checked by removing the cover and holding the contacts closed manually after the unit has started. Set the centrifugal disconnect switch gap at approximately .025 inches for proper wipe and contact pressure. Should the centrifugal switch S1 fail to open on shutdown, it will cause a battery discharge and burn out of the emergency time delay relay (K14).

REV. DES.	PART NO.	QTY.	DESCRIPTION
B1	1	1	STARTER & SOLENOID
B1	1	1	BATTERY 12V
E1	1	1	FUEL PUMP
HRI	1	1	HEATER-MANFOLD
HRI-3	2	2	HEATER-GLOW PLUG (2 CYL)
HRI-5	4	4	HEATER-GLOW PLUG (4 CYL)
K1	1	1	SOLENOID-FUEL
307-0628	1	1	SWITCH-CENTRIFUGAL
S1	1	1	SWITCH-HIGH TEMP
S2	1	1	SWITCH-LOW TEMP
S4	1	1	SWITCH-LOW OIL PRESS
AC PARTS LIST			
G21	1	1	GENERATOR
R21	304-0709	1	RESISTOR ASSY
VR22	305-0532	1	REGULATOR ASSY-VOLTAGE [MVD V ADJ]-01,-02,-03,-05,-06,-08,-09,-10
VR23	305-0533	1	REGULATOR ASSY-VOLTAGE [M/V ADJ]-03,-04,-07,-08,-11,-12
W9	338-0794	1	WIRING HARNESS (F1-F2)
CONTROL BOX PARTS LIST			
CR11	305-0494	1	RECTIFIER & LEAD ASSY
K11	307-0845	1	RELAY-START SOLENOID
K12	307-0823	1	RELAY-START DISC & FUEL SOLENOID
K13	307-1046	1	RELAY-MANFOLD HEATER
K14	320-004	1	RELAY-EMERGENCY (LOP)
M11	302-0448	1	AMMETER-CHARGE 5-0-5
R11,S11	308-0307	1	SWITCH & RESISTOR ASSY
R12	304-0897	1	RESISTOR-LEAD ASSEMBLY
S12	308-0304	1	SWITCH & LEAD ASSY
TB11	332-0604	1	TERMINAL BLOCK
332-0616	1	1	MARKER STRIP
TB12	332-0706	1	TERMINAL BLOCK
332-0739	1	1	MARKER STRIP
W1	336-1468	1	LEAD ASSY
W2	336-2289	2	LEAD ASSY
W3	336-1470	1	LEAD ASSY
W4	336-1465	2	LEAD ASSY
W5	336-0779	1	LEAD ASSY
W6	332-0802	1	JUMPER
W7	336-1470	1	LEAD ASSY
W8	336-1045	2	LEAD ASSY
301-1961	1	1	PANEL-CONTROL BOX
301-1962	1	1	CONTROL BOX
301-3714	1	1	COVER-REGULATOR
301-3483	1	1	SADDLE-CONTROL BOX
301-3482	1	1	OUTPUT BOX-04,-02,-03,-04
301-0856	1	1	COVER-04,-02,-03,-04
301-2467	1	1	OUTPUT BOX-05 THRU -12
301-2466	1	1	COVER-05 THRU -12
508-083	1	1	GROMMET
402-0070	4	4	RUBBER MOUNTS
337-0036	1	1	GROUND STRAP
98-1683	1	1	SILASCREEN/ADDC LOW OIL & RESET
98-2406	1	1	SILASCREEN/ADDC/S3CR1-05 THRU -11
98-2407	1	1	SILASCREEN/IBR1-02 THRU -12

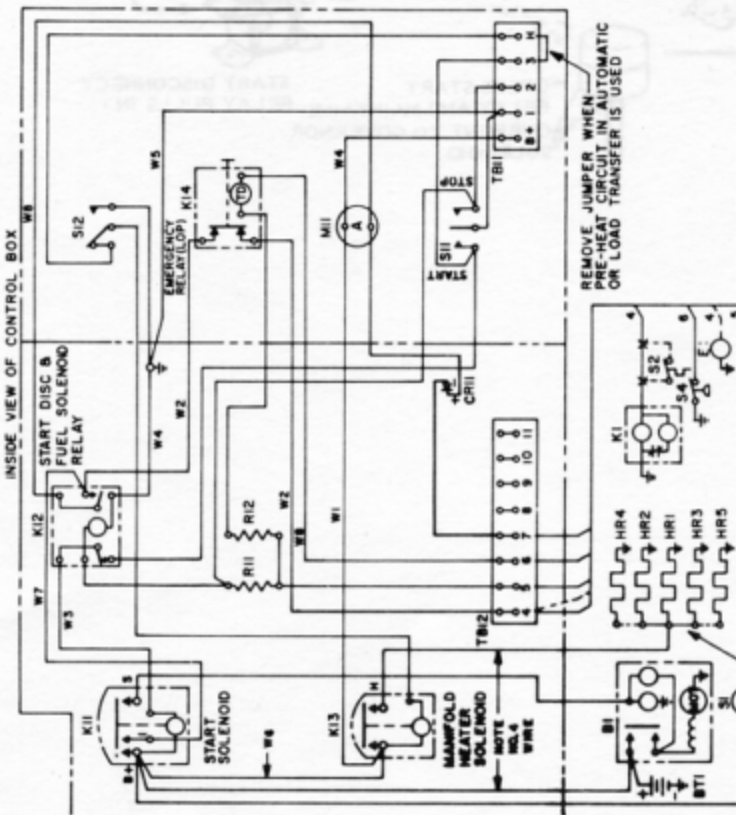
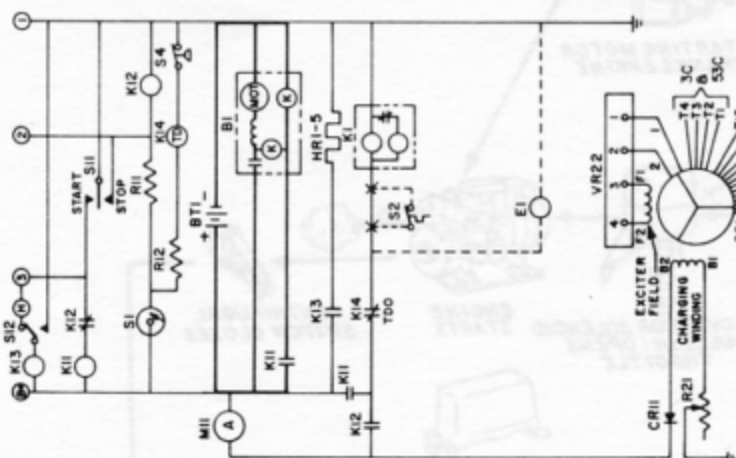

REMOVE JUMPER WHEN PRE-HEAT CIRCUIT IN AUTOMATIC OR LOAD TRANSFER IS USED

NOTES
 1. CONNECT LEAD W10 FROM V4 TO V-
 PER VOLTAGE CHART BELOW.
 2. CONNECT X1 TO 5 FOR CODE 53C & 51B (50HZ)
 3. UNLESS OTHERWISE NOTED, ALL COMPONENTS
 ARE SHOWN IN THE DE-ENERGIZED POSITION.

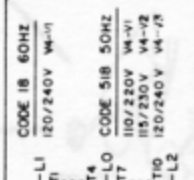

CODE	V4-V1	V4-V2	V4-V3	V4-V4
CODE 1B 60HZ	120/240V	120/240V	120/240V	120/240V
CODE 51B 50HZ	110/220V	115/230V	120/240V	120/240V

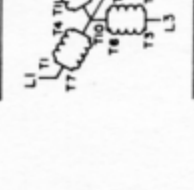
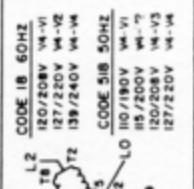
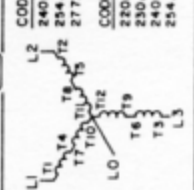
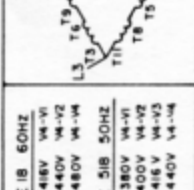
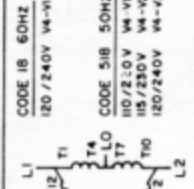

WHEN USED

MODEL NO.	VR22	VR23	VR22	VR23
4 CYL	4 CYL	4 CYL	MARINE	MARINE
SCR B	-01	-03	-05	-07
53CR	-02	-04	-06	-08
51B	-08	-10	-12	-12

NOTE: (B) MARINE (C) MARINE

STANDARD DIESEL
CONTROL 612-4792

DIESEL STARTING SEQUENCE

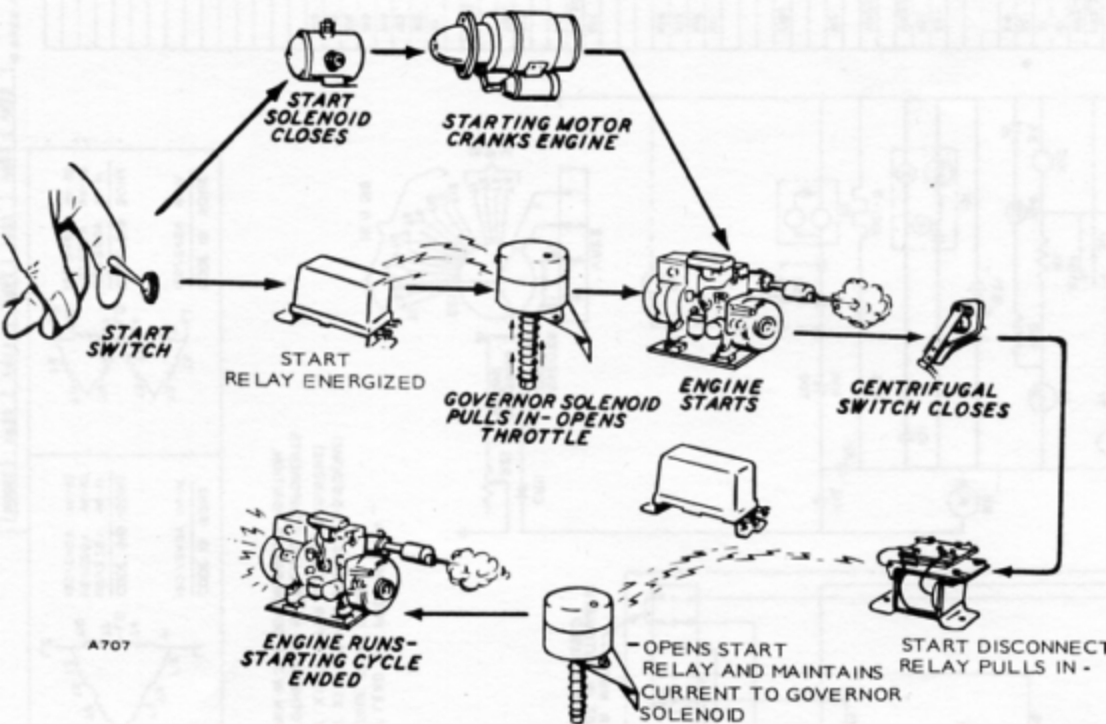

A707

WIRING DIAGRAM

INSIDE VIEW OF CONTROL BOX

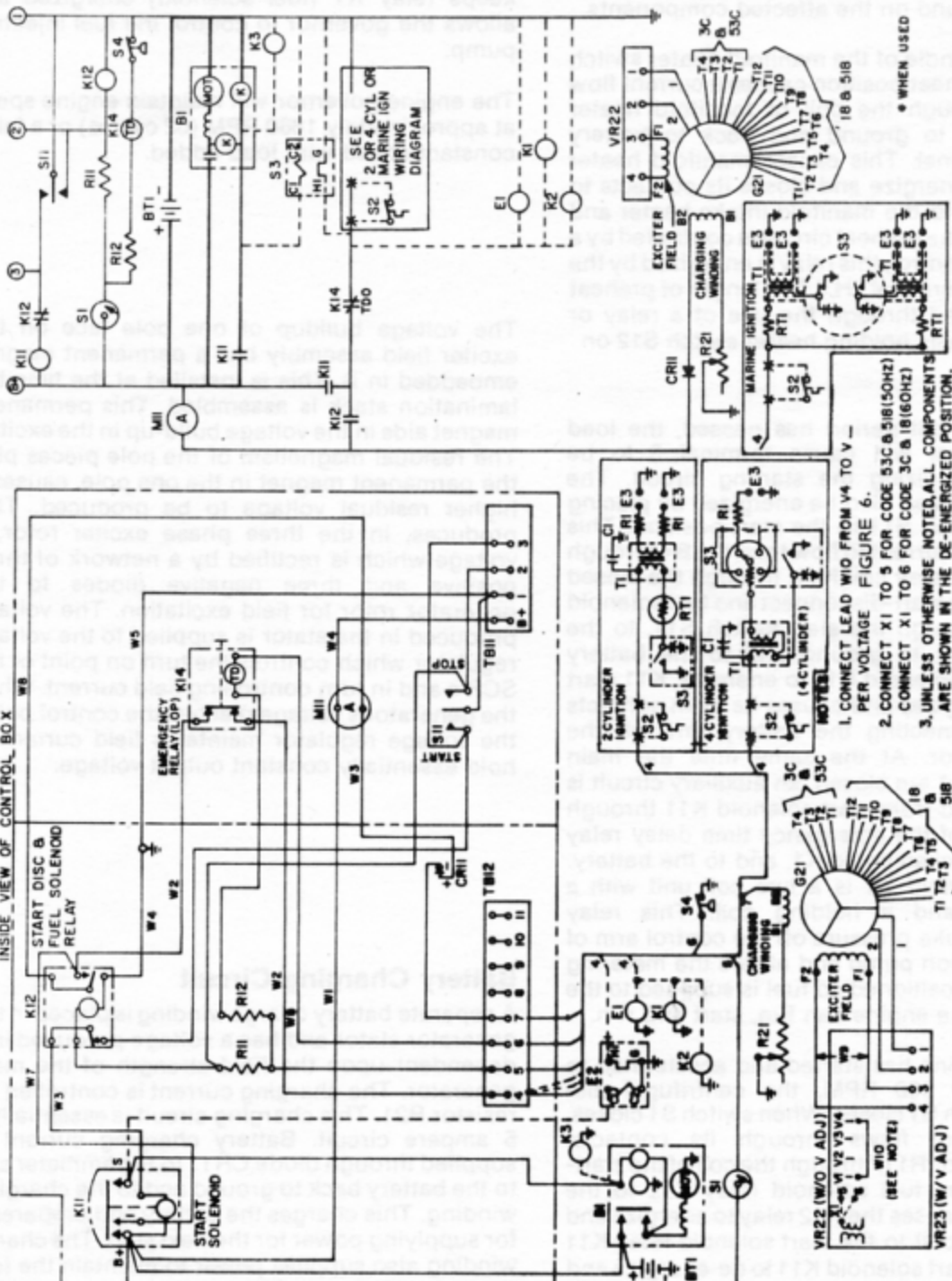

SCHEMATIC DIAGRAM

REF. DES.	PARTS LIST (REV.)	DESCRIPTION
B1	STARTER & SOLENOID-ENGINE	
B11	BATTERY	24
E1	FUEL PUMP	
E2	CHOKE & THERMO MAG	
E3	SPARK PLUG (2 CYL)	
E3	SPARK PLUG (4 CYL)	
E4	SOLENOID-FUEL	
E5	SOLENOID-OIL TANK FUEL	
B1	SOLENOID-PRIMER	
B1	SOLENOID-SPARK PLUG (2CYL)	
B1	SOLENOID-SPARK PLUG (4CYL)	
BT1	RES-HYTEMCO 172-A-25W (2CYL)	
BT1	RES-HYTEMCO 172-A-15W (MARINE)	
S1	SWITCH-CENTRIFUGAL	
S2	SWITCH-HIGH TEMP	
S3	BREAKER ASSY	
S4	SWITCH-LOW OIL PRESS	
F1	COIL-IGNITION	
F1	COIL-IGNITION (MARINE)	
G21	GENERATOR	
R21	RESISTOR ASSY	
VR22	REGULATOR ASSY-VOLTAGE	
VR22	W/O V ADJ-O1-O2-O3-O4-O5-O9-10	
VR23	REGULATOR ASSY-VOLTAGE	
VR23	W/V ADJ-O1-O2-O3-O4-O5-O8-11-12	
W9	WIRING HARNESS (F1-F2)	
CR11	RECTIFIER & LEAD ASSY	
K11	RELAY-START SOLENOID	
K12	RELAY-START DISC & IGNITION	
K14	RELAY-EMERGENCY (LOP)	
M11	AMMETER-CHARGE 0-0-5	
M11,B1	SWITCH & RESISTOR ASSY	
TB11	TERMINAL BLOCK	
TB12	TERMINAL BLOCK	
W1	LEAD ASSY	
W2	LEAD ASSY	
W3	LEAD ASSY	
W4	LEAD ASSY	
W5	LEAD ASSY	
W7	LEAD ASSY	
W8	LEAD ASSY	

• WHEN USED

- NOTES
1. CONNECT LEAD W10 FROM V4 TO V - PER VOLTAGE FIGURE 6.
 2. CONNECT X1 TO 5 FOR CODE 53C & 51B(50HZ)
 3. CONNECT X1 TO 6 FOR CODE 3C & 1B(60HZ)
3. UNLESS OTHERWISE NOTED, ALL COMPONENTS ARE SHOWN IN THE DE-ENERGIZED POSITION.

JB, JC, AND MJC MODELS
WITH LOW OIL PRESSURE SWITCH

MODEL	WIRING HARNESS (REV.)	DESCRIPTION
6.0	12-5KW-518R/56AA	
6.0	12-5KW-518R/56AA	
7.5	15.0KW-3CR/56AA	
7.5	15.0KW-3CR/56AA	
10.0	15.0KW-3CR/1AA	
10.0	15.0KW-3CR/1AA	
183PH, 50 & 60HZ		

CONTROL-GEN SET (WIRING DIAGRAM)
612-4794

OPERATING SEQUENCE FOR DIESEL GENERATING SET CONTROL #611-1082

Starting Circuit

The common practice for placing "Onan" Class "A" controls into operating condition is by grounding certain components. The switch is used to place this ground on the affected components.

Moving the handle of the manifold heater switch S12 to the preheat position causes a current flow from B+, through the coil of manifold heater solenoid K13 to ground and back to battery negative terminal. This causes manifold heater relay K13 to energize and closes its contacts to supply power to the manifold intake heater and glow plugs. If the preheat circuit is controlled by a load transfer control, this relay is energized by the grounding of terminal "H." The length of preheat can be selected through the use of a relay or through manually holding heater switch S12 on.

After the preheat period has passed, the load transfer control will cause terminal 3 to be grounded energizing the starting circuit. The starting circuit can also be energized by placing start-stop switch S11 in the start position. This allows battery current to flow from the B+ through start solenoid relay coil K11, through the closed contacts of the start-disconnect and fuel solenoid relay K12, through the start switch S11, to the center terminal to ground and to the battery causing start solenoid K11 to energize. K11 start solenoid energizes and causes its main contacts to close, connecting the battery through the cranking motor. At the same time the main contacts of K11 are closed, an auxiliary circuit is also completed from start solenoid K11 through the contacts of the emergency time delay relay K14, to the fuel solenoid K1, and to the battery. The fuel solenoid K1 is a two coil unit with a pickup coil and a holding coil. This relay energizes to take pressure off the control arm of the fuel injection pump and allows the metering sleeve to be positioned so fuel is supplied to the injectors so the engine can fire, start and run.

When the engine has started and accelerated to approximately 900 RPM, the centrifugal disconnect switch S1 closes. When switch S1 closes, battery current flows through its contacts, through resistor R11, through the coil of the start-disconnect and fuel solenoid relay K12 to the battery. This causes the K12 relay to energize and breaks the circuit to the start solenoid relay K11 causing the start solenoid K11 to de-energize and remove the cranking motor from the battery. At

the same time, another set of K12 contacts close supplying power from the charging circuit or the battery through the normally closed contacts of emergency relay K14 to the fuel solenoid K1. This keeps relay K1 (fuel solenoid) energized and allows the governor to control the fuel injection pump.

The engine governor will maintain engine speed at approximately 1860 RPM (62 cycles) or a fairly constant speed with load added.

The voltage buildup of one pole face on the exciter field assembly has a permanent magnet embedded in it. This is installed at the time the lamination stack is assembled. This permanent magnet aids in the voltage build-up in the exciter. The residual magnetism of the pole pieces plus the permanent magnet in the one pole, causes a higher residual voltage to be produced. This produces, in the three phase exciter rotor, a voltage which is rectified by a network of three positive and three negative diodes to the generator rotor for field excitation. The voltage produced in the stator is supplied to the voltage regulator which controls the turn on point of the SCR's and in turn controlling field current. When the generator's voltage reaches the control point, the voltage regulator maintains field current to hold essentially constant output voltage.

Battery Charging Circuit

A separate battery charge winding is placed in the generator stator and has a voltage produced in it dependent upon the field strength of the main generator. The charging current is controlled by resistor R21. This charging circuit is essentially a 5 ampere circuit. Battery charging current is supplied through diode CR11 to the ammeter and to the battery back to ground and to the charging winding. This charges the battery and prepares it for supplying power for the next start. The charge winding also supplies power to maintain the fuel solenoid K1, energized.

Low Oil Pressure Cut-Out (LOPKO)

The low oil pressure cutout circuit is from the battery side of the ammeter through the centrifugal disconnect switch S1 to resistor R12, through the heater of the emergency time delay relay K14 and through the low oil pressure switch S4 to ground. Resistor R12 sets the timing interval of emergency relay K14. Should there be a loss of oil pressure or an excessive drop in level, switch S4 will close and the emergency time delay relay K14 will operate in approximately 15 seconds. When time delay relay K14 operates due to low oil pressure, its normally closed contacts open and break the circuit to the fuel solenoid K1. The fuel solenoid de-energizes and its plunger drops down on the control arm of the fuel injection pump causing the fuel to spill and shuts down the engine.

Unit Stopping

To stop the engine it is necessary to ground terminal #2 through the load transfer control or to place start-stop switch S11 in the stop position. Grounding terminal #2 or placing start-stop switch S11 in the stop position causes a ground to be placed on the supply side of the start-disconnect and fuel solenoid relay K12. Relay K12 de-energizes, its contacts open and break the circuit to the fuel solenoid K1 causing engine shutdown. Resistor R11 is placed in the circuit so a short circuit or dead ground is not placed on the battery charging circuit.

Fast Troubleshooting

If the ammeter does not indicate a charge, it usually means the generator has not built up voltage. This generator does not have an automatic field flash circuit; and consequently, it is necessary to make a field voltage measurement. This can be done across terminals 3 and 4 at the end bell of the generator or at terminal 7 or 8 of the voltage regulator assembly. Terminal 8 is positive and terminal 7 is negative. Should no voltage be measured at these points, refer to the "YD" Generator Service Manual (900-0184).

The water-cooled units have a high water temperature cutoff switch S2 in series with the fuel solenoid K1. This switch can be checked by placing a jumper across the terminals of the switch and closing the start switch S11 to see if the solenoid energizes.

If there has been a low oil pressure cutout condition, the red button on the emergency relay K14 will be sticking out. One minute of "cool down" is required before resetting (pushing in the button) the relay to place it back in operation. A shorter time may result in the solder pot not fusing correctly and permitting the button to be pushed out by the spring when the unit vibrates.

Should the centrifugal switch S1 fail to close or make contact, the start-disconnect and fuel solenoid relay K12 will de-energize as soon as the start switch S11 is released and then the unit will shut down. This causes a cycling condition on the generator set. The centrifugal switch S1 can be checked by removing the cover and holding the contacts closed manually after the unit has started. Set the centrifugal disconnect switch gap at approximately .025 inches for proper wipe and contact pressure. Should the centrifugal switch S1 fail to open on shutdown, it will cause a battery discharge and burn out of the emergency time delay relay K14.

Emergency Shutoffs

The control also has provision for connecting an alarm circuit to indicate low oil pressure and high temperature and overspeed. Should an overspeed or high temperature condition present itself, relay K16 will energize. This is a latching relay which has to be reset after one of the mentioned conditions has occurred. When relay K16 energizes its contacts open, breaking the circuit to the fuel solenoid (K1) shutting the engine down. When the fault condition has been corrected, the K16 relay must be reset by pushing the button which protrudes from the control.

Should a low oil pressure condition exist, the switch S3 closes and after approximately 15 seconds K15 operates and breaks the circuit to the fuel solenoid causing engine shutdown. This device has an added unit to it whereby a circuit is made to activate a low oil pressure alarm. The high temperature-overspeed will also complete an alarm circuit to activate an alarm to indicate a fault.

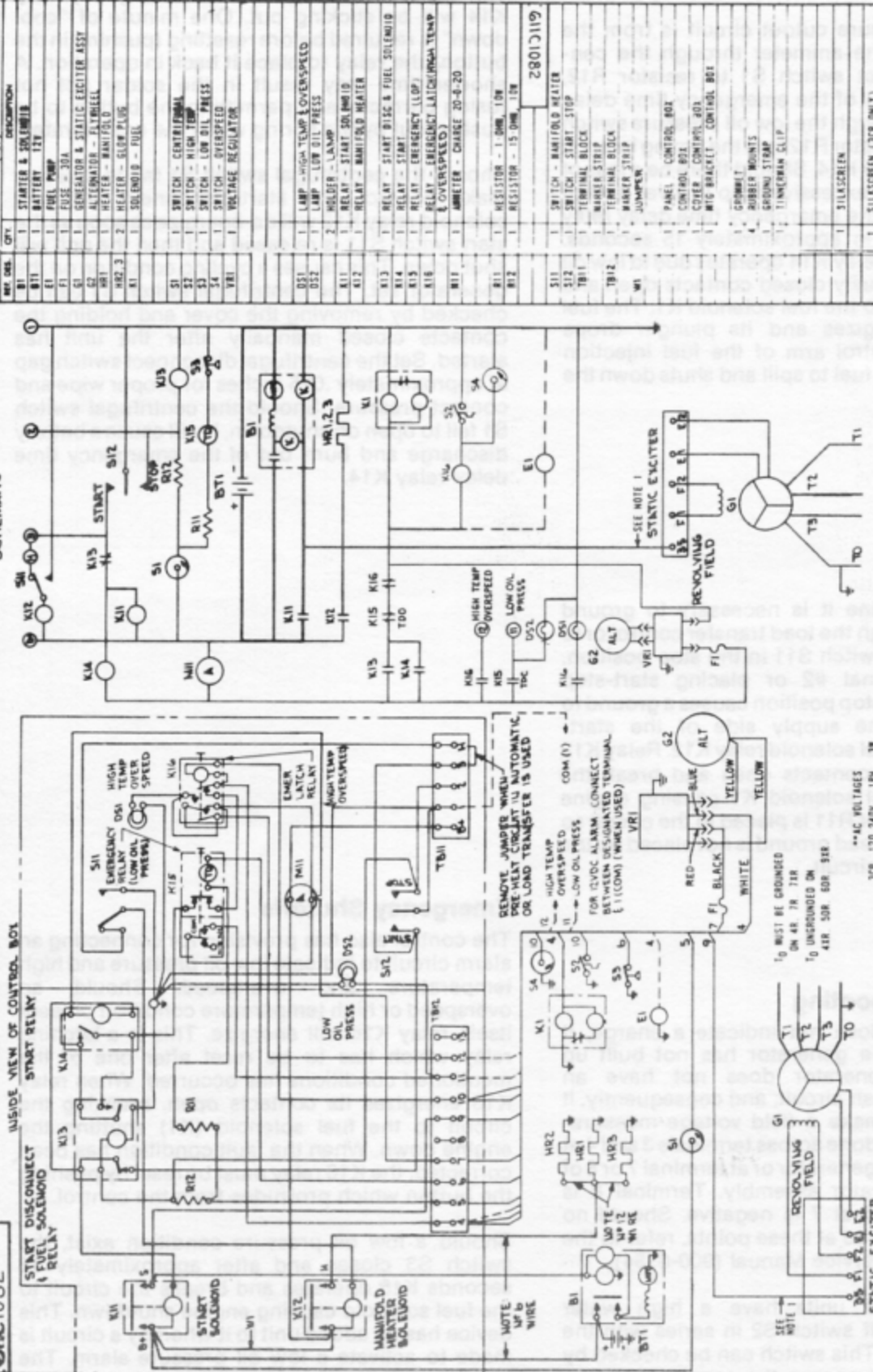

REF. DES.	QTY	QIN PARTS LIST (REF.)	DESCRIPTION
B1	1	STARTER & SOLENOID	
B2	1	BATTERY 12V	
E1	1	FUEL PUMP	
F1	1	FUSE - 30A	
G1	1	GENERATOR & STATIC EXCITER 45T	
G2	1	ALTERNATOR 120/240V	
H1	1	HEATER - MANIFOLD	
H2, 3	2	HEATER - R/W P/WR	
K1	1	SOLENOID - FUEL	
S1	1	SWITCH - CENTRIFUGAL	
S2	1	SWITCH - HIGH TEMP	
S3	1	SWITCH - LOW OIL PRESS	
S4	1	SWITCH - OVERSPEED	
VR1	1	VOLTAGE REGULATOR	
DS1	1	LAMP - HIGH TEMP OVERSPEED	
DS2	1	LAMP - LOW OIL PRESS	
K11	1	RELAY - START SOLENOID	
K12	1	RELAY - START SOLENOID	
K13	1	RELAY - START B1 & FUEL SOLENOID	
K14	1	RELAY - START	
K15	1	RELAY - EMERGENCY (LSP)	
K16	1	RELAY - EMERGENCY LATCH (HIGH TEMP & OVERSPEED)	
BT1	1	AMBIETER - CHARGE 20-4-20	
R11	1	RESISTOR - 1 OHM, 10W	
R12	1	RESISTOR - 15 OHM, 10W	
S11	1	SWITCH - MANIFOLD HEATER	
S12	1	SWITCH - START STOP	
TR1	1	TERMINAL BLOCK	
TR2	1	TERMINAL BLOCK	
W1	1	WIRE STRIP	
			JUMPER
			PANEL - CONTROL BOX
			CONTROL BOX
			COVER - CONTROL BOX
			WIG BRACKET - CONTROL BOX
			GUMMETS
			ROBBER MOUNTS
			SPRING STRAP
			TINNERSMAN CLIP
			SILKSCREEN
			SILKSCREEN (2-DIG. ONLY)

DIESEL CONTROL

611-1082

QIN	DASH
KW	NO
SCR	-01
ALL OTHERS	-02

***AC VOLTAGES
 SCR 120 240V 1PH 3W
 48 120 208V 3PH 4W
 50R 120 240V 3PH 4W
 50R 240 480V 3PH 4W
 51R 270 540V 3PH 4W
 51R 320 640V 3PH 4W
 51R 340/510V 3PH 4W
 51R 347/509V 3PH 4W

1₀ MUST BE GROUNDED ON 4R 7R 7IR
 1₀ UNGROUNDED ON 41R 50R 50R 51R

SINGLE PHASE AC LOAD CONNECTIONS (SCR)

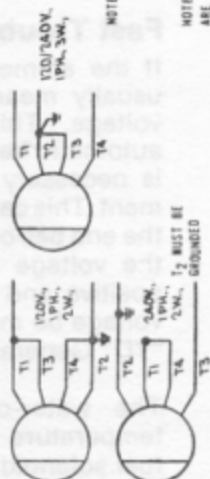

NOTE 1 THIS WIRE USED FOR SCR 4R 7R 7IR ONLY

NOTE 2 UNLESS OTHERWISE NOTED ALL COMPONENTS ARE SHOWN IN THE DE ENERGIZED POSITION

Starting Circuit

The common practice for Onan controls is to ground the center of the switch portion of all start-stop switches. The operation of the control is accomplished through grounding certain components.

Moving the handle of the manifold heater switch S11 to the heat position energizes the manifold solenoid K12, which then supplies battery power through the main contact of relay K12 to the glow plugs and the manifold heater. This switch should be held in this position for 30 seconds normally or if weather conditions are such that extreme cold is encountered, then for either one minute or two minutes.

After a sufficient pre-heat time has been allowed, placing the start-stop switch S12 in the start position causes a current flow from the B+ terminal of start solenoid K11 to the coil, to the start-disconnect and fuel solenoid relay K13. Then from this point through the normally closed contacts of that K13 relay, to the start side of the start-stop switch S12 to terminal one on the terminal connection block to ground. This energizes the start solenoid K11 and supplies battery power to the solenoid shift on the cranking motor and then to the starter, cranking the engine.

Battery voltage is picked up at the ammeter and this causes a current flow to the coil of the start relay K14 through the coil to the normally closed contacts on the K13 relay to the start switch S12 and to ground. This causes the start relay K14 to energize. From the battery a current flows through the ammeter, through it to the start relay K14 contacts, which are now closed, through the contacts on the emergency relay K15. (This is a low oil pressure relay and its heater is energized when the unit starts and if the low oil pressure switch fails to open.) Through these contacts to the terminal 4 on the terminal block, to the high temperature cut-out switch S2, to the fuel solenoid K1. This energizes the fuel solenoid K1 and allows the governor to position the metering sleeve in the fuel injection pump to full fuel. With the manifold heater switch S11 released and the start switch S12 still closed, the starter solenoid K11 and the manifold heater solenoid K12 remain energized. Battery power is supplied to the glow plugs and manifold heater and to the cranking motor.

Start-Disconnect Circuit

The cranking motor continues to crank the engine until it starts and accelerates. 900 RPM is the speed at which the centrifugal switch S1 has been set to operate. The centrifugal switch S1 is driven by a gear from the camshaft gear. As centrifugal force is high enough the weights fly out allowing the cam to drop in and the centrifugal disconnect closes. When the centrifugal switch S1 closes, battery power is supplied through this switch to the 15 ohm, 10 watt resistor R12, to the coil of the start disconnect and fuel solenoid relay K13 and to ground. This energizes K13 relay causing the normally closed contacts to open and break the start solenoid K11 circuit. This also de-energizes the coil on the start relay K14. The contact in the start relay K14 opens just after the contacts in the start-disconnect and fuel solenoid relay K13 close. This supplies power to the fuel solenoid K1 and keeps it energized so that it does not release and cause the injection pump control metering sleeve to go to minimum fuel and stop the engine.

The engine governor maintains the engine speed at rated value for that particular unit. In this case it is 1800 RPM.

Battery Charging Circuit

When the engine has come up to speed the residual magnetism in the rotor poles produce a small voltage in the battery winding of the generator. A consequent voltage build up is produced. When voltage has built up to normal then the battery charge winding in the stator has a voltage produced in it which is directed through the charge rectifier CR11 to the charge ammeter to the battery terminal on the manifold heater solenoid K12 and to the battery, recharging it. The charge resistor R1, is adjustable for the most satisfactory charge rate. It is factory set at approximately 5 amperes. The charge rectifier CR11 replaces the reverse current relay used in earlier models. It is a battery charge diode and this unit has only the one step of battery charging.

REF. DES.	QTY.	DESCRIPTION
B1	1	STARTER & SOLENOID
BT1	1	BATTERY 12V
E1*	1	FUEL PUMP
G1	1	GENERATOR & STATOR EXCITER ASS
HR1	1	HEATER-MANIFOLD
HR2-5	4	HEATER-GLOW PLUG
K1	1	SOLENOID-FUEL
R1	1	RESISTOR-CHARGE ASSY
S1	1	SWITCH-CENTRIFUGAL
S2*	1	SWITCH-HIGH TEMP
S3	1	SWITCH-LOW OIL PRESS
CONTROL BOX PARTS LIST		
CR11	1	DIODE-RECTIFIER
K11	1	BRACKET-RECTIFIER MTG
K12	1	RELAY-START SOLENOID
K13	1	RELAY-MANIFOLD HEATER
K14	1	RELAY & LEAD ASSY
K15	1	RELAY-START IGN
M11	1	RELAY-EMERGENCY (LOP)
R11	1	AMMETER-CHARGE 5-0-5
S11	1	RESISTOR-1 OHM, 10W
S12	1	SWITCH-TOGGLE
S12	1	SWITCH & RESISTOR ASSY
R12	1	SWITCH-START/STOP
RB11	1	RESISTOR 15 OHM, 10W
TB11	1	TERMINAL BLOCK
TB12	1	MARKER STRIP
W1	1	MARKER STRIP
W1	1	JUMPER
W2	1	LEAD ASSY 2"
W3	1	LEAD ASSY 13-1/2"
W4	1	LEAD ASSY 7"
W5	1	LEAD ASSY 8"
W6	2	LEAD ASSY 9"
W7	2	LEAD ASSY 12"
W8	1	LEAD ASSY 12"
W8	1	PANEL-CONTROL BOX
W8	1	CONTROL BOX
W8	1	COVER-CONTROL BOX
W8	1	BRACKET-CONTROL BOX MTG
W8	1	BRACKET-OUTPUT BOX
W8	1	GROMMET
W8	4	MOUNTS
W8	1	STRAP-GROUND
W8	1	COVER-OUTPUT BOX
W8	1	OUTPUT BOX
W8	1	GROMMET (OUTPUT BOX)
W8	1	SILKSCREEN (ADD LOW OIL & RESET)
W8	1	SILKSCREEN (3CR ONLY)

* WHEN USED

**STANDARD MARINE
DIESEL CONTROL**
612-2334

SCHEMATIC

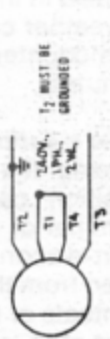
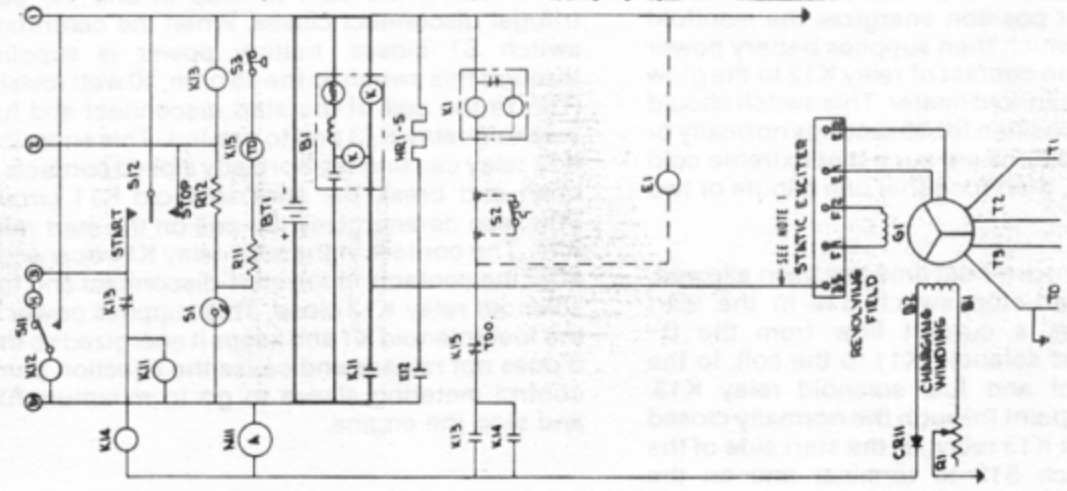

WIRING DIAGRAM

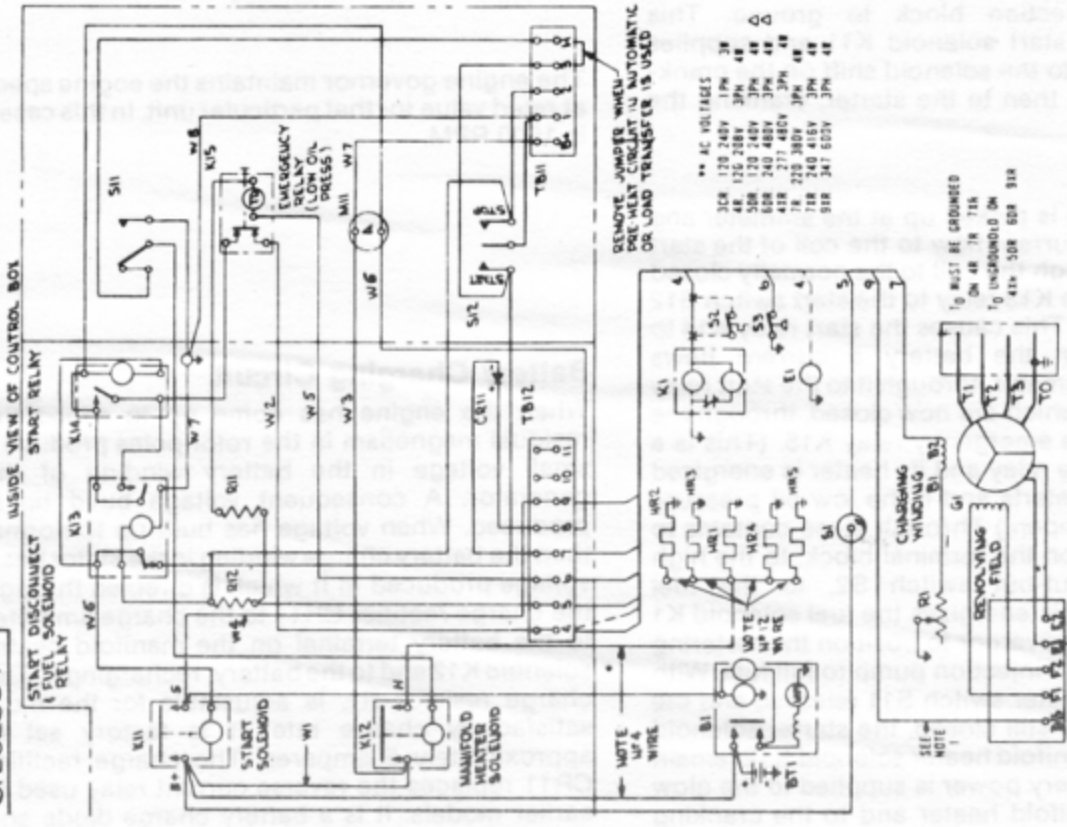

SINGLE PHASE AC LOAD CONNECTIONS (3CR)

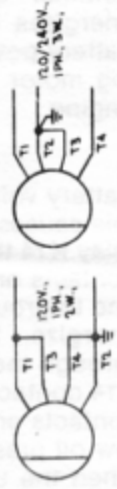

NOTE 1 THIS WIRE USED FOR 3CR 4R 7R 7R ONLY

NOTE 2 UNLESS OTHERWISE NOTED ALL COMPONENTS ARE SHOWN IN THE DE ENERGIZED POSITION

Low Oil Pressure Cut Off (LOPKO)

The one ohm, 10 watt resistor R11 is to limit the current through the heater on the emergency relay K15. This heater gets current only after the generator has come up to a certain speed and centrifugal switch S1 has closed. Should low oil pressure remain for 15 seconds, the heater HR1 will allow the ratchet to release and contacts will open breaking the circuit to the fuel solenoid K1 causing a shut down.

Unit Stopping

Placing the start-stop switch S12 in the stop position, shorts out the power supply to the start-disconnect and fuel solenoid relay K13 and breaks the circuit to the fuel solenoid K1. The K1 solenoid shaft applies force to the injection pump

control arm causing positioning of the metering sleeve to "No fuel" position. The engine stops due to lack of fuel to the injectors. Fuel removal is the only means provided for stopping the Onan diesel.

Fast Troubleshooting

The ammeter indicating "0" usually means the generator has not built up voltage. This generator has an automatic field flash circuit which receives power from the "F" terminal of the start solenoid K11. When K11 start solenoid is energized, power is applied to the static exciter and to the revolving field for faster voltage build up. The 12-volt battery used does not cause damage to the exciter nor to the revolving field due to the high cranking current causing a substantial voltage drop across the battery and reducing this voltage to approximately 8-volts.

Should the centrifugal switch S1 fail to close or make contact, the start-disconnect and fuel solenoid relay K13 will not energize and as soon as the S12 start switch is released the unit will shut down. This can be readily checked by taking the cover off the S12 switch and holding contacts closed manually. It also can be checked by taking the cover off the control box and holding the start-disconnect and fuel solenoid relay K13 armature closed by hand. Should centrifugal switch S1 fail to open on shut down, it will cause a battery discharge and also cause the operation of the emergency relay K15.

"J" SERIES UNITS

STARTING SEQUENCE-DIESEL POWERED UNITS

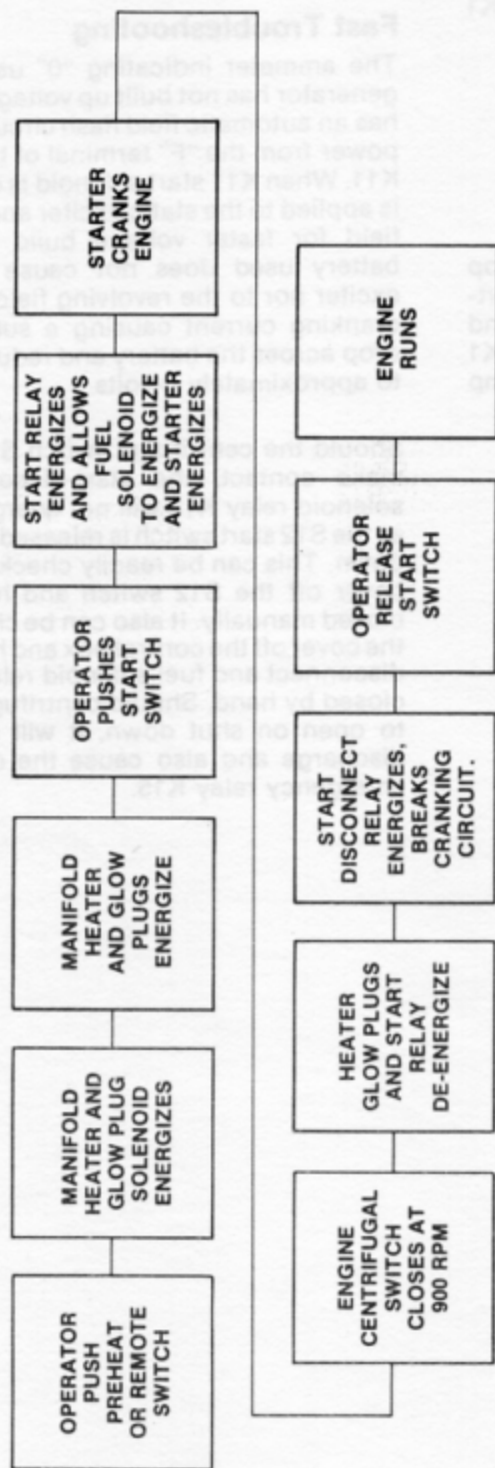

STOPPING SEQUENCE DIESEL

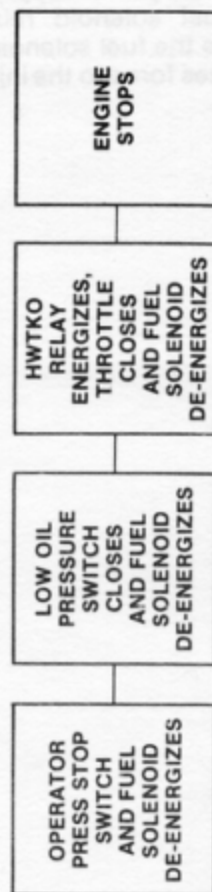

Starting Sequence

The starting and stopping sequence shows the manual, mechanical, and electrical events required for satisfactory start, run and stop cycles.